

Glue Down Specifications

- Wear Layer: 22 mil (0.55 mm)
- Overall Thickness: 2.5 mm
- **Chevron** Size: 4.5" x 22.5"
- **Herringbone** Size: 6" x 24"
- 100% Phthalate Free
- Reach Compliant
- Warranty: Lifetime Residential and 20-Year Heavy Commercial

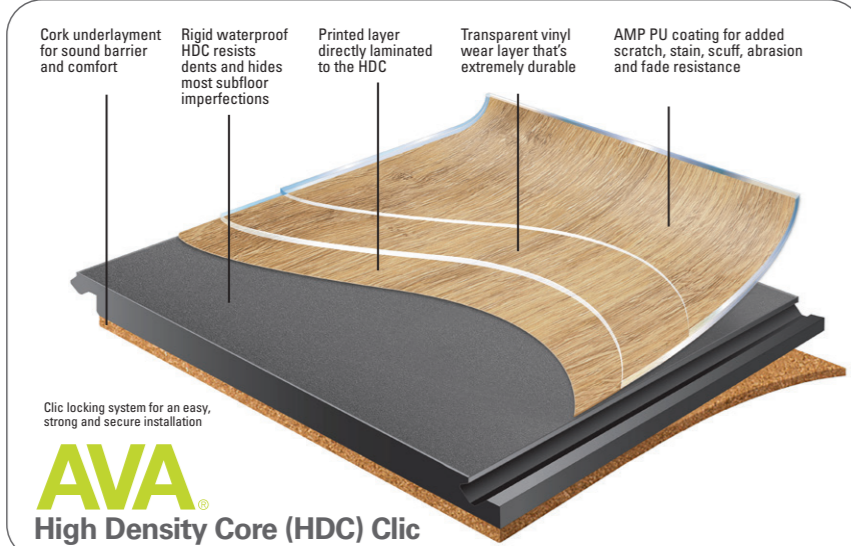
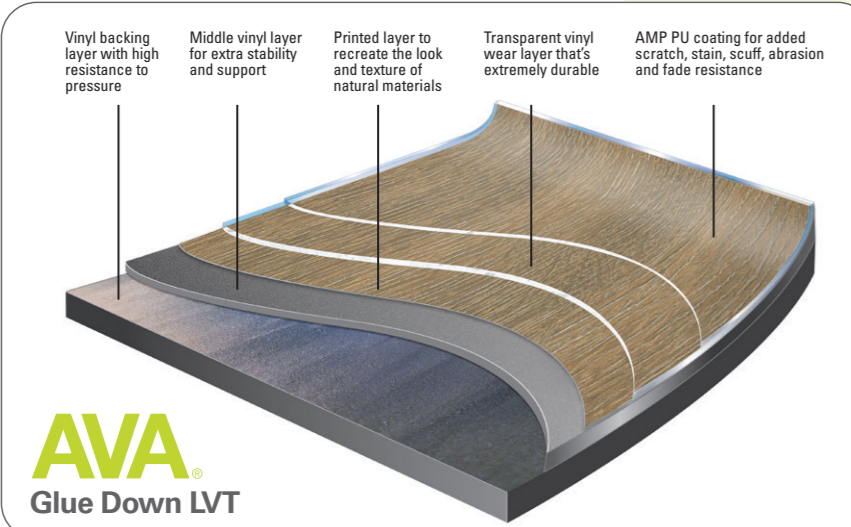

HDC Clic Specifications

- Wear Layer: 22 mil (0.55 mm)
- Overall Thickness: 6.0 mm
- **Chevron** Size: 5.71" x 26.2"
- **Herringbone** Size: 5.71" x 29.25"
- 100% Phthalate Free
- 1.0 mm Cork Underlayment
- Reach Compliant
- Warranty: Lifetime Residential and 15-Year Light Commercial

- Patented Coating
- 30% More Scratch Resistance Over Typical Coatings
- Exceptional Wear Resistance and High Strength
- High-gloss finish

	GLUE DOWN	HDC CLIC
ASTM F1700 SOLID VINYL TILE:	CLASS III, TYPE B	
ASTM F2055 SIZE:	PASSES, ± 0.4 MM	
ASTM F2055 SQUARENESS:	PASSES, ± 0.25 MM	
ASTM F387 PRODUCT THICKNESS:	PASSES, ± 0.13 MM	PASSES, ± 0.2 MM (W/ FOAM LAYER)
ASTM F410 WEAR LAYER THICKNESS:	PASSES, ± 0.5 MM	PASSES, ≥ 0.5 MM
ASTM F1914 RESIDUAL INDENTATION:	PASSES, ≤ 0.2 MM	PASSES, ≤ 0.18 MM
ASTM F1914 SURFACE INTEGRITY:		PASSES, NO PUNCTURE
ASTM F137 FLEXIBILITY:	PASSES, 25.4 MM MANDREL	
ASTM F2199 DIMENSIONAL STABILITY:	PASSES, <0.5 MM PER LIN. FT.	
ASTM F925 CHEMICAL RESISTANCE:	PASSES ASTM F1700 REQUIREMENTS	PASSES ASTM F3621 REQUIREMENTS
ASTM F1514 RESISTANCE TO HEAT:	PASSES, < Δ8E	PASSES, < Δ8E
ASTM F1515 RESISTANCE TO LIGHT:	PASSES, < Δ8E	PASSES, < Δ8E
ASTM F970 STATIC LOAD (MODIFIED):	≤ 0.4 MM INDENT, 1,500 LBS.	PASSES, ≤ 0.13 MM INDENT, 250 LBS.
ASTM E648 (NFPA 253) CRITICAL RADIANT FLUX:	CLASS I, >0.45 W/CM²	CLASS I, >0.45 W/CM²
ASTM E662 (NFPA 258) SMOKE DENSITY:	PASSES, <450	PASSES, <450
ASTM D2047 / UL 410 SLIP RESISTANCE:	>0.5 SCOF (NO RAMPS)	>0.5 SCOF (NO RAMPS)
ASTM F3261 RIGID CORE SPECIFICATION:		CLASS I, TYPE B, GRADE 1, BACKING CLASS B
ISO 24337 SIZE & SQUARENESS:		PASSES, ± 1.5 MM SIZE, ± 0.25 MM SQUARENESS
ISO 24337 FLATNESS:		PASSES, ± 0.2 MM WIDTH, < 0.2% LENGTH
ISO 24337 JOINT OPENING:		PASSES, ≤ 0.2 MM
ISO 24337 JOINT LEDGING:		PASSES, ≤ 0.15 MM
ISO 23999 DIMENSIONAL STABILITY:		PASSES, ≤ 0.2% / LIN. FT.
ISO 23999 CURL:		PASSES, ≤ 2 MM
ASTM E492 / E989 IMPACT INSULATION CLASS:		CHEVRON: IIC 53*, 51Y, 64S / HERRINGBONE: IIC 53*
ASTM E90 / E413 SOUND TRANSMISSION CLASS:		CHEVRON: STC 51*, 59Y, 62S / HERRINGBONE: STC 53*
ASTM E2179 DELTA IMPACT INSULATION CLASS:		CHEVRON: ΔIIC 22* / HERRINGBONE: ΔIIC 21*

* 6" concrete | V 18" OWT | 56" concrete, gypsum ceiling



With worldwide sales offices and distribution partners, AVA is a leader in the design and manufacturing of innovative and sustainable resilient flooring. Established in 1984, AVA has developed a diverse range of designs and products that have won numerous awards and are recognized by the industry as setting the benchmark in LVT.

AVA® and SWAY™ are trademarks of Novalis' Innovative Flooring.

© 2024 Novalis' Innovative Flooring



avaflor.com • 877.861.5292
sales@avaflor.com



Herringbone, English Oak Veil

AVA SWAY



NOVALIS
INNOVATIVE FLOORING

AVA SWAY

AVA SWAY



Chevron, Vienna Oak Manor

With impressive patterns and efficient installation, AVA SWAY™ Chevron and Herringbone planks bring timeless elegance and style without the hassles. Pre-cut specifically for less material waste, easier installation and precise fit, SWAY™ is available in six colors in both formats: 2.5 mm glue-down construction and 6.0 mm HDC clic.

SWAY™ with our proprietary AMP coating, stands up to high traffic areas in a variety of Residential and Commercial applications. SWAY™ is FloorScore® certified and is phthalate free, Greenguard Gold certified, has Declare label, EPD & HPD.





Chevron, Alabaster Oak Sierra

Chevron — Glue Down: 4.5" x 22.5" / HDC: 5.71" x 26.2"



Acacia Oak Primrose

Chevron Glue Down: AC001CHEV-2555
Chevron HDC: AC001SCHEV-655C

Herringbone Glue Down: AC001HERR-2555
Herringbone HDC: AC001SHERR-655C

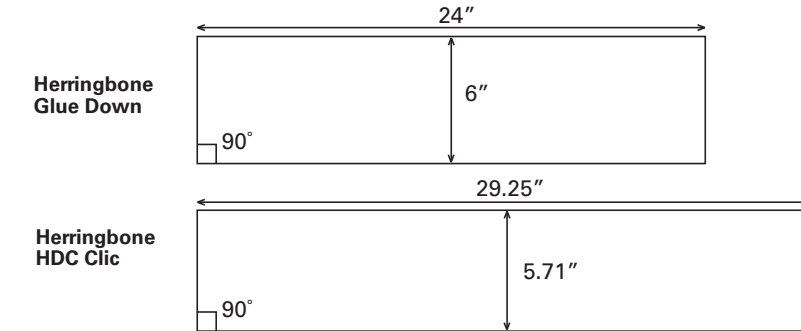
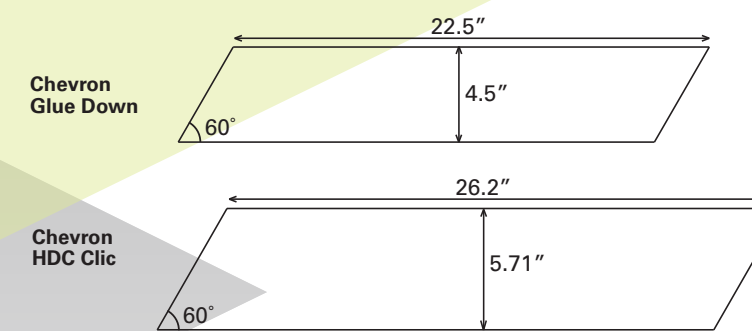

Alabaster Oak Sierra

Chevron Glue Down: AB001CHEV-2555
Chevron HDC: AB001SCHEV-655C

Herringbone Glue Down: AB001HERR-2555
Herringbone HDC: AB001SHERR-655C

Herringbone — Glue Down: 6" x 24" / HDC: 5.71" x 29.25"



Alabaster Oak Villa

Chevron Glue Down: AB002CHEV-2555
Chevron HDC: AB002SCHEV-655C

Herringbone Glue Down: AB002HERR-2555
Herringbone HDC: AB002SHERR-655C



English Oak Toffee

Chevron Glue Down: EO001CHEV-2555
Chevron HDC: EO001SCHEV-655C

Herringbone Glue Down: EO001HERR-2555
Herringbone HDC: EO001SHERR-655C



Herringbone, English Oak Toffee, Acacia Oak Primrose



Herringbone, Alabaster Oak Villa



English Oak Veil

Chevron Glue Down: EO002CHEV-2555
Chevron HDC: EO002SCHEV-655C

Herringbone Glue Down: EO002HERR-2555
Herringbone HDC: EO002SHERR-655C



Vienna Oak Manor

Chevron Glue Down: VO001CHEV-2555
Chevron HDC: VO001SCHEV-655C

Herringbone Glue Down: VO001HERR-2555
Herringbone HDC: VO001SHERR-655C