

Product Overview

AVA FAVE is a click-and-lock High Density Core (HDC) product that features a full line of popular wood looks that provide a wide range of design options for many applications. FAVE is a true rigid core product with an attached foam backing,

which greatly improves its sound reduction characteristics without the use of a separate sound control product. FAVE is constructed with a waterproof core, a durable wear layer and our proprietary AMP polyurethane coating,

making it an ideal flooring product for single family homes, multi-family units, condominiums, and a variety of other residential environments. FAVE is made in the USA.

Product Information

Product Type: **Drop Lock Rigid Core**
 Core Type: **High Density Core (HDC)**
 Overall Thickness: **5mm & 5.2mm**
 Wear Layer Thickness: **12 mil (0.3mm)**
22 mil (0.55mm)
 Underlayment Thickness & Type: **1.0mm XPO Foam**
 Finish: **AMP Polyurethane Coating**
 Surface: **Embossed w/ Microbevel**

Residential Warranty: **Lifetime**
 Commercial Warranty - 12 mil: **10 Years**
 Commercial Warranty - 22 mil: **15 Years**
 Dimensions: **5.75" x 47.75"**
 Carton Quantity: **10 Planks (19.06 sq. ft.)**
 Carton Weight: **34 lbs.**
 Cartons / Pallet: **54**

Technical Information

| | |
|--|--|
| ASTM F3261 - Rigid Core Specification: | Class I, Type B, Grade 1, Backing Class B |
| ISO 24337 - Size & Squareness: | Passes, ± 1.5 mm size, ± 0.25 mm squareness |
| ASTM F387 - Thickness of Flooring w/ Foam Layer: | Passes, ± 0.2 mm |
| ASTM F410 - Wear Layer Thickness: | Passes, ≥ 0.5 mm |
| ISO 24337 - Flatness: | Passes, ± 0.2 mm width, < 0.2% length |
| ISO 24337 - Joint Opening: | Passes, ≤ 0.2 mm |
| ISO 24337 - Joint Ledging: | Passes, ≤ 0.15 mm |
| ASTM F1914 - Residual Indentation: | Passes, ≤ 0.18 mm |
| ASTM F1914 - Surface Integrity: | Passes, no puncture |
| ISO 23999 - Dimensional Stability: | Passes, ≤ 0.2% / lin. ft. |
| ISO 23999 - Curl: | Passes, ≤ 2 mm |
| ASTM F925 - Chemical Resistance: | Passes ASTM F3621 requirements |
| ASTM F1514 - Resistance to Heat: | Passes, < ΔE 8 |
| ASTM F1515 - Resistance to Light: | Passes, < ΔE 8 |
| ASTM F970 - Static Load: | Passes, ≤ 0.13 mm indent, 250 lbs. |
| ASTM E648 (NFPA 253) - Critical Radiant Flux: | Class 1, > 0.45 W/cm2 |
| ASTM E662 (NFPA 258) - Smoke Density: | Passes, < 450 |
| ASTM D2047 / UL 410 - Slip Resistance: | > 0.5 SCOF (no ramps) |
| ASTM E492 / E989 - Impact Insulation Class: | 5mm - IIC 56^{*y}, 66^s |
| | 5.2mm - IIC 57^{*y}, 55^y, 67^s |
| ASTM E90 / E413 - Sound Transmission Class: | STC 50[*], 60^y, 61^s |
| ASTM E2179 - Delta Impact Insulation Class: | ΔIIC 25[*] |

* 6" concrete | ¥ 18" OWT | §6" concrete, gypsum ceiling

Disclaimer: These test results were independently tested, using material from standard production, in accordance with product-specific standard test methods. Physical and performance testing may vary, within tolerances, depending on the testing apparatus and/or production lot used. Be sure to use the most recently published versions of all reference documents, specifications and test methods. To purchase the most recent version of the above mentioned ASTM or ISO standards, please visit www.astm.org. or www.iso.org, respectively. Test reports are available upon request.

1. GENERAL INFORMATION

Accessories

Coordinating flooring accessories, including t-moldings, reducers and stair nosings, are available for FAVE. For more information, contact a sales agent or e-mail sales@avaflor.com for more information.

Silicone Caulk

Matching 100% silicone caulk is available for all FAVE colors. For more information, contact a sales agent or e-mail sales@avaflor.com for more information.

Sales & Technical Support

AVA products are sold through a nationwide network of sales agents. For information about who to contact in your area, please contact sales@AVAflor.com. Additional technical resources and documents are available online at AVAflor.com. For additional technical support, contact support@AVAflor.com.

Limitations

The optimal operating temperature for use is between 40°F to 90°F (4°C to 32°C). Avoid prolonged exposure to direct sunlight or other heat sources where temperatures will exceed 90°F (32°C), as discoloration or damage may occur. This product is not suitable for heavy rolling loads or heavy commercial areas. Do not install in areas that may be subjected to sharp, pointed objects, such as stiletto heels, cleats or spikes. Do not allow product to be directly exposed to extreme heat sources, such as self-cleaning ovens or other high-heat equipment. Do not install outdoors or in areas that may be exposed to repeated and sustained UV/IR rays, as product may fade, discolor or experience excessive movement. Refer to the Material Usage Guide and, if applicable, the Wet Areas technical bulletin for a full list of acceptable areas and information about approved areas of use. Do not use rubber tires, casters or rubber-backed walk-off mats directly on the flooring surface, as permanent staining may occur. Do not install nails, screws, bolts, moldings, accessories or heavy fixed furniture, such as cabinets, counter tops, islands or commercial

equipment, directly on, into or through the flooring material, as this may restrict the natural movement of the floor and cause gapping/buckling.

2. PRE-INSTALLATION

Receiving Material & Storage

Remove all plastic and strapping from the product after delivery. Confirm that the flooring product color, style and quantity are correct, and check lot numbers, in the event you've received more than one. Carefully check all materials for shipping damage and note all damage on the bill of lading before accepting the delivery. Material accepted with visible shipping damage that is not reported on the bill of lading is not covered under warranty. The floor covering and accessories must be stored in dry indoors conditions between 40°F to 90°F (4°C to 32°C). Do not store outside (even in containers) and do not stack pallets.

Recommended Tool List

- ▶ Appropriate Personal Protective Equipment (PPE)
 - Safety Glasses, Cut-Resistant Gloves, Suitable Dust Mask, etc.
- ▶ Appropriate Tools & Machinery for Substrate Preparation
 - Floor Buffer, Grinder, Floor Scraper, etc.
- ▶ HEPA-Filtered Vacuum
- ▶ 6-ft. and 1-ft. Straight Edge or Level with two quarters (U.S. coins)
- ▶ Tape Measure
- ▶ Pencil
- ▶ Speed Square
- ▶ Utility Knife with New Blades
- ▶ Chalk Marking Line
- ▶ 2 lb. rubber/soft faced dead blow hammer (preferred) or rubber mallet
- ▶ Wedge Spacers
- ▶ Pull-bar
- ▶ Jigsaw with Carbide Blades (for complicated cuts)
- ▶ Oscillating Multi-Tool or hand saw (for door jambs)
- ▶ Non-Contact Infrared Thermometer
- ▶ Knee Pads

Warning

All local, state, and federal regulations must be followed; this includes the removal of in-place asbestos flooring and adhesive, as well as any lead-containing materials. The Occupational Safety and Health Administration (OSHA) has exposure limits for people exposed to respirable crystalline silica; this requirement must be followed. Do not use solvent or citrus-based adhesive removers. When appropriate, follow the Resilient Floor Covering Institute's (RFCI) Recommended Work Practice for Removal of Existing Floor Covering and Adhesive. Always wear safety glasses and use respiratory protection or other safeguards to avoid inhaling any dust. The label, installation, and maintenance instructions along with the technical data sheet, limited warranty and any appropriate Safety Data Sheet (SDS) of all products must be read, understood, and followed prior to installation. Do not leave spills unattended - wipe up promptly, and allow the floor covering to dry before trafficking.

Documentation

Record and/or photograph the site conditions, test results, and any corrective measures taken. All relevant pre-installation documentation, as well original product invoices and associated shop drawings or project information, should be stored for the entire warranty period.

Site Conditions

The prepared installation area must be fully enclosed and weather-tight. During the installation, any direct sunlight should be blocked using window treatments or other protection. The ambient temperature during installation must be >60°F (16°C), with a recommended maximum of 80°F (27°C). The flooring does not require an acclimation period.

To ensure that temperature conditions are maintained throughout installation, a wireless, cloud-based environmental condition monitoring system may be used to check site conditions when the site is unoccupied.

To ensure that temperature conditions are maintained throughout installation,

a wireless, cloud-based environmental condition monitoring system may be used to check site conditions when the site is unoccupied.

Note: When installing at temperatures >80°F (27°C), the width of the expansion gap may increase as the flooring temperature decreases.

3. SUBSTRATE PREPARATION

General Substrate Guidelines

Ensure the substrate is clean, dry, flat, sound and suitably prepared according to these instructions prior to installation, as manufacturer is not responsible for problems related to substrates that have not been properly prepared. All substrates must be free of visible water or moisture, dust, residual adhesives and adhesive removers, solvents, wax, oil, grease, asphalt, visible alkaline salts or excessive efflorescence, mold, mildew and all other extraneous coating, film, material or foreign matter. Substrate and/or subfloor deflection, movement, or instability may cause issues with the flooring installation – these are not covered under warranty.

Flatness Guidelines

Check all substrates for flatness prior to installation. All substrates must have a floor flatness of FF32 and/or have a maximum deviation of $\leq 1/8$ -in. gap (2 x US quarters should not slide underneath) within 6-ft. and $\leq 1/16$ -in. gap (1 x US quarter should not slide underneath) within 1-ft. Substrates that do not meet this requirement must be corrected appropriately before installation begins.

Concrete Substrate Requirements

All concrete substrates must be at least 28-days old, free of contaminants and structurally sound. If required, flatten and/or smooth the surface using a suitable, moisture-resistant, commercial-grade leveling or patching compound, following the product instructions. Do not install if water or hydrostatic pressure is visible, present or suspected. If a chemical adhesive remover has been used, contact the technical department. For all on and below grade concrete substrates refer to "Concrete Moisture Requirements".

All expansion joints must have a suitable expansion joint covering system installed to allow for expansion and contraction of the concrete. All dormant construction joints and surface cracks > 1/4-in. must be cleared of all dust, dirt and debris and filled with a rigid crack treatment designed for use in construction joints or cracks. Follow the products instructions and ensure surface is troweled flush with surface of concrete.

Concrete Moisture Requirements

For all On and/or Below Grade concrete substrates, test the surface to confirm it is absorbent (porous). Follow the ASTM F3191 Standard Practice for Field Determination of Substrate Water Absorption (Porosity) for Substrates to Receive Resilient Flooring - water droplet(s) placed on the surface must be absorbed into the concrete within 60-mins. for the surface to be considered absorbent. If required, the concrete can be made porous by mechanical methods, such as diamond grinding, a DiamaBrush buffer attachment, shotblasting or similar.

If the substrate cannot be made porous and will not have a topical moisture mitigation system installed, install a ≥ 6 -mil thick polyethylene (PE) sheet, which is available at most home improvement stores. Use sheeting that is ≤ 10 -ft. wide to prevent wrinkles and folds. Sheeting must be installed over the entire area and extend at least 2-in. up the walls. All seams must be overlapped and sealed according to the product instructions.

Lightweight/Gypsum Substrates

Lightweight or gypsum substrates must be dry (according to the product manufacturer's requirements) and have a minimum compressive strength of 2000 PSI when installed over a wood substrate or 3000 PSI when installed over a concrete substrate. Lightweight or gypsum substrates must be installed and prepared in accordance with ASTM F2419 or ASTM F2471, respectively. Lightweight and gypsum substrates must be firmly bonded to a structurally sound subfloor. All cracked or fractured areas must be removed and repaired with a compatible

repair product. New or existing lightweight or gypsum substrates may require a sealant or primer be installed prior to resilient flooring installation - follow the product manufacturer's recommendations regarding preparation for resilient flooring.

Wood Substrate Requirements

All wood substrates must be structurally sound, dry and within the moisture content percent (MC%) for your region. Wood substrates and subfloors must be compliant with and, if necessary, prepared in accordance with ASTM F1482. Wood substrates should be of double layer construction with a recommended total thickness of 1-in. or more, depending on federal, state and local building codes. Sleepers and sleeper systems must not make direct contact with concrete.

Resinous Coating Requirements

When installing directly over a resinous coating, such as an epoxy coating or a moisture mitigation system, ensure the coating is clean and free of contaminants, structurally sound, smooth, dry and has cured for the prescribed length of time.

Metal Substrate Requirements

Metal substrates must be clean, dry, structurally sound smooth and free of oil, rust and/or oxidation. When installing in areas that may be subject to topical water, moisture and/or high humidity, an anti-corrosive coating should be applied to protect the metal substrate. Contact a local paint or coating supplier for coating recommendations.

Other Substrates

Installing over existing resilient vinyl flooring is not recommended. However, it may be possible over some materials, such as VCT, quartz tile, solid vinyl tile, sheet vinyl or linoleum, as well as existing hard surface flooring substrates, such as terrazzo, porcelain or ceramic tile. Ensure existing flooring is a single layer and is clean, dry, sound, solid and well adhered. All loose material must be removed and repaired or replaced. All grout lines and wide seams greater than 1/4-in. in width and/or depth, as well as any significant substrate imperfections, must be filled and troweled flush with a suitable

cementitious patch. By electing to install over any existing floor covering releases the manufacturer from any responsibility regarding the suitability and continued performance of that product, including any resulting effect on the new floor covering.

Radiant Heating Requirements

When installing flooring over a substrate that contains a radiant heating system, ensure that none of the heating elements make direct contact with the flooring material. Ensure radiant heat is no higher than 70° F (21° C) 8-hours prior to and during the entire installation. After installation, the radiant heat may be gradually increased over the course of 24 hours, until normal operating temperature is reached. Ensure the temperature of the radiant heating system does not exceed 85° F (29.5° C) and avoid making abrupt changes in radiant heating temperature.

Sound Control Substrates

AVA Rigid Core products may be installed over AcoustiCork Endurance, but may not be installed with any other sound control products, such as cork, foam or rubber underlayments.

For more information, please see the AVA Sound Control technical bulletin.

Unsuitable Substrates

These include, but are not limited to: any floating or loose floor coverings, hardwood, VAT, carpet, cushioned vinyl, rubber, cork, foam, asphalt tile, additional acoustical underlayments and any substrate with visible mold, mildew, or fungi and any substrate in wet areas, such as inside showers and saunas. Do not install directly over any adhesive or adhesive residue of any kind. Do not install in recreation vehicles, campers or boats.

Note: Existing hardwood floor coverings will swell when exposed to moisture - vinyl floor covering may restrict the movement of moisture in hardwood, which may result in flooring failure, especially when installed on or below grade. Some hardwood floor coverings may also discolor vinyl floor covering. Issues related to unsuitable substrate are

not covered under warranty.

4. FLOORING EXPANSION

Expansion Gap

Expansion gaps are required around the entire perimeter of the flooring and between the flooring and all adjacent vertical surfaces, such as adjacent flooring, fixed furniture, thresholds, fixtures, door jambs, and other protrusions - this allows the flooring area to freely expand and contract naturally. Do not adhere or anchor any accessories directly to or through the flooring material, as this could restrict natural movement resulting in an installation failure. The required expansion gap depends on the installation area, per the following:

- Areas that are ≤ 50 feet in length and/or width must have a ≥ 1/4-in. expansion gap.
- Areas that are 50-85 feet in length and/or width must have a ≥ 1/2-in. expansion gap.
- Three season rooms, sun rooms and other areas that will not have continuous HVAC control must have a ≥ 1/2-in. expansion gap.
- Hotel rooms that may undergo high-heat pest control must have ≥ 1/2-in. expansion gap.
- Areas with very heavy furniture ≥ 800-lb. (363-kg) must be isolated with a compatible t-molding and have ≥ 1/2-in. expansion gap.

Expansion Joint

When the total flooring length or width exceeds 85 feet, a compatible t-molding must be installed to create an expansion joint. Expansion joints must be wide enough to accommodate an appropriate accessory and allow for the appropriate expansion gap on either side. Accessories must cover the flooring material by at least 1/8-in. on each side and must be glued or anchored directly to the substrate.

Three season rooms, sun rooms and other areas that will not have continuous HVAC control must be ≤30 feet in length and/or width and must be isolated from other areas with a compatible t-molding,

to ensure that flooring does not run room to room.

5. FLOORING INSTALLATION

Installation Preparation

All wall-base should be removed before flooring installation. Alternately, a quarter round molding (fixed to the wall or wall-base only) may be used. Undercut all wooden door jambs and the first -in. of any remaining wall-base (later covered with molding) with an Oscillating Multi-Tool - the height must be the thickness of the floor covering plus 1/64-in., which will allow the floor covering to expand and contract naturally. Steel door jambs should be pattern-scribed, leaving the required expansion gap. Use a color-coordinated 100% silicone to fill the void. Clean the entire area to be installed using a HEPA-filtered vacuum.

Inspect all material prior to and during installation to verify that there are no visible defects, damages and excessive shading, sheen or texture variations. Blend materials from several cartons within the same lot to ensure a consistent appearance. Some flooring products, colors and textures have latent and acceptable color and shade variations. If there are concerns regarding defects, shade, sheen or texture variation, do not install material and consult a sales representative or manufacturer's technical staff. **Labor costs associated with materials installed with obvious visual defects will not be covered under warranty.**

Although mixing different lots within the same area will not affect the performance of the product, it is not recommended, as shade, sheen and texture variations may be visible. Prior to installing, compare different lots side-by-side from all directions and lighting conditions to confirm acceptability for the owner or end-user. **Material installed with obvious visual differences related to production lots will not be covered under warranty.**

Layout

Prior to installation, confirm the installation pattern and direction per the design specifications or work order.

Planks should be installed in a random pattern - plank end joints should be randomly spaced by ≥ 8 -in. Avoid "H" joints and do not install in a "Stair-Stepped" installation pattern, while ensuring no obvious pattern repeats emerge. Failure to randomize the end joints could weaken the integrity of the locking mechanism, which may lead to failure. Tiles must be installed in a brick-bond or 1/3rd off-set pattern.

Starting Line

Determine the best wall to start the installation along – typically, this is the longest straight wall with a doorway. Measure the width of both ends of the room and, accounting for the necessary expansion gaps, calculate the width of your last row. If it is less than half the width of the floor covering or if a balanced design is required, reduce the width of the first row accordingly. Use a chalk-line to mark the outside edge of the first row on the substrate.

If needed, trim the first row by removing the side without the extended locking mechanism (tongue) to fit, accounting for the expansion gap. To trim the first row, either measure and mark your cutlines or use the mirror-scribe method. To mirror-scribe, place your selected piece on the opposite side of the chalk-line, so that the chalk-line is above the extended locking mechanism (tongue). Then, place a full piece flush with the wall, overlapping your selected piece. Using the overlapped piece as your guide, mark a cutline on your selected piece with a pencil. Once marked, proceed with trimming the first row as detailed below.

Cutting

To cut the floor covering, carefully score along the cut line at least twice with a sharp utility knife. When cutting across the width of a piece, use a speed square as a guide. Snap the piece downwards and, if necessary, trim the attached underlayment from underneath. For complicated cuts, such as around fixtures or door jambs, use a jigsaw with a carbide blade, following the tool's safety instructions.

First Row (slide)

At the left corner of the starting wall,

position the first piece so that either the pre-cut side or the side without the extended locking mechanism (tongue) is flush with the wall. Place wedge spacers between the floor covering and the wall to maintain the required expansion gap. Before connecting the second pre-cut piece, lay it flat on the substrate, adjacent to the first row and lined up with the end of the previous piece. Then, while keeping the joint aligned, slide the ends together, locking the joint into place.

Complete the entire first row using this

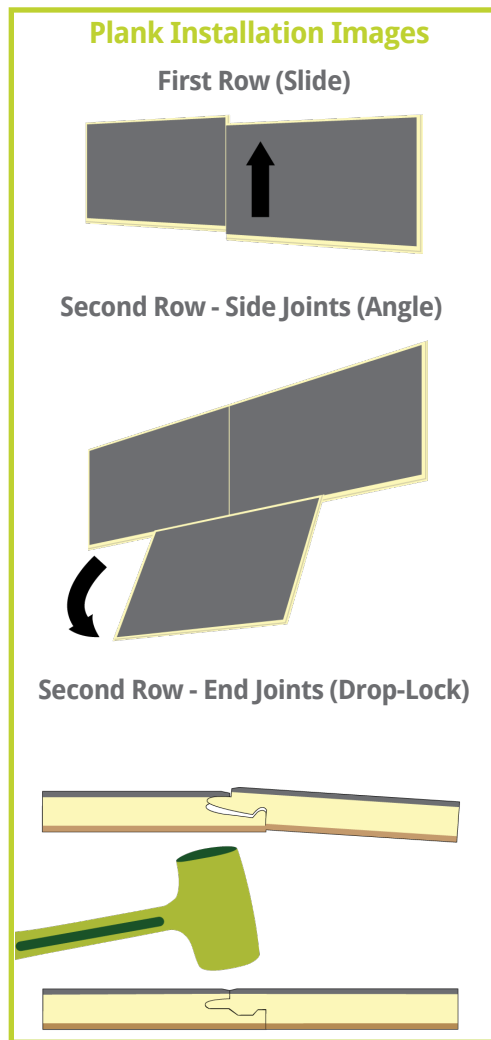

method. When you reach a doorway, make sure the cut edge will be covered by the door jamb and frame while maintaining the required expansion gap. Keeping the installation straight is critical - check the first row using a chalk line or similar and adjust or reinforce the entire row with wedge spacers as needed

to prevent movement. The acceptable straightness tolerance is within 1/16-in. for > 20-ft. lengths or 1/32 -in. for < 20-ft. lengths. Begin the following rows with a cut piece, perhaps from a previous row, and follow the "Side Joints" detail below.

Side Joints (angle)

Starting at the left corner, typically with a cut piece, insert the side without an extended locking mechanism (tongue) into the previous row at a $\sim 25^\circ$ angle. Make sure it is properly seated and slides freely, then slide the piece into position. The end joint must either be flush with the wedge spacer (first piece) or be closely aligned with the end of the previous piece. Lay the piece flat and complete the end joint as detailed below.

End Joints (drop-lock)

Before locking end joints into place, check the alignment at the joint and adjust as necessary. To engage the locking mechanism, lightly tap along the raised piece using a 2-lb. (~ 32 -oz.) soft faced dead blow hammer (preferred) or rubber mallet. Keep the striking head flat with the floor covering and tap until the joint is completely flush. If the end joint is not properly aligned, it may break - pieces with damaged or broken locking mechanisms must be removed per the process below. When replacing damaged pieces, adjust the straightness of the row and/or the alignment of the joint prior to engaging end joints to prevent further damage.

Flooring Removal

If you need to replace a piece or disengage the end joints for any reason, first unlock the side joints of the entire row by raising the outside edge of the row by $\sim 25^\circ$, then disconnect the row from the installation. Once the row is removed, ensure that all pieces are lying flat and are properly engaged, then slide each piece apart. If pieces do not slide easily, the locking mechanism may not be fully engaged – simply tap the piece with a dead blow hammer or rubber mallet to fully engage and slide apart. Do not separate pieces by angling them or pulling them upward, as this will break the locking mechanism.

Additional Installation Tips

Do not hit any part of the locking mechanism directly with any hammer, tapping block or pull bar unless it is the last row - doing so will damage the locking mechanism and may result in peaking, gapping and joint separation. If you need to tighten gaps in the installation, use a ~6-in. piece of scrap floor covering, seated in the locking mechanism, and lightly tap to close any joints.

If you need to install small pieces that are < 3-in. in length or width, place a thin bead of Liquid super glue on the previously installed locking mechanism just before installing. This will ensure the joints remain locked together during use. Do not get the adhesive on the surface, be prepared and if required, immediately remove adhesive using isopropyl alcohol with a clean white cloth - super glue coverage should be ~30 feet per oz.

After the first five or six rows are completed, turn the installation process around so that you are working on top of the installed material. This will allow the side joints to be pulled together rather than pushed, which will make the installation easier.

6. POST-INSTALLATION

Visually inspect the installation to ensure that the appearance is uniform and straight, that the locking mechanisms are fully engaged, that all seams are tight and correctly staggered/spaced, and that the expansion gap is the correct width. Trim off any excess plastic sheeting as necessary. Fill any perimeter gaps that will not be covered by an accessory with a 100% silicone, color-coordinated caulk. When spot cleaning, do not apply abrasive or solvent-based cleaners directly to the surface of the floor covering. When covering perimeter gaps with an accessory (wall base, molding, thresholds, t-molding, etc.), ensure the accessory overlaps the flooring material by at least 1/8-in.. All accessories must be glued or anchored directly to the substrate or vertical surface. When required, protect newly installed flooring with construction grade paper or protective boards, such

as Masonite, Ram Board or plywood, to prevent damage from other trades. Take photographs and have any required documentation signed and filed following completion. Save three or more extra pieces of material in the original packaging as attic stock for the lifetime of the floor. **In the unlikely event of a product issue, attic stock can play a crucial role in product identification, color matching, product claim verification and possible repairs.**

7. INITIAL MAINTENANCE

Residential

Dust-mop or vacuum the floor to remove any dirt or debris. Damp-mop the floor as often as required using a flat microfiber mop or a spray mop. Use a pH neutral, film-free and streak-free cleaner concentrate, available at home improvement stores, and make sure to change the pad as often as necessary. Steam cleaners with a micro-fiber head may also be used, providing the steaming head is never stationary, as prolonged, excessive heat can damage any vinyl floor covering.

Commercial

Dust-mop or vacuum the floor to remove any dirt or debris. Mix a pH neutral, film-free and streak-free cleaner with clean, cool potable water and damp-mop or spot clean the floor as often as necessary. Avoid wet mopping, puddling or pooling cleaning liquid on the surface.

For further information regarding daily or routine maintenance, please consult the product care & maintenance document or the associated product technical data sheet.

8. FLOORING PROTECTION

Do not slide or drag heavy objects across the floor. When moving appliances, heavy furniture or equipment, protect the flooring with appropriate, hard surface furniture sliders or 1/2 in. plywood.

All furniture casters or glides must be intended for resilient flooring and made of a soft material, such as a felt, silicone

or a poly-based material. Casters and glides must have a flat contact point that is at least 1 sq. in. or 1.125 in. in diameter to limit indentation and flooring or finish damage. All rolling seating in desk areas must have chairs that use soft, W-Type polyurethane wheels and have a polycarbonate resilient flooring chair pad installed over the finished floor to protect it. **To avoid maintenance-related issues, do not use nylon/hard plastic wheels, glides or casters.**

All fixed furniture legs or corners must have permanent floor protectors installed on all contact points to reduce indentation, wear, scratching and other flooring or finish damage. Floor protectors must be intended for resilient flooring and made of a soft material (such as a felt, silicone or a poly-based material). Floor protectors must have a flat contact point of at least 1 sq. in. or 1.125 in. diameter and must cover the entire bottom surface of the furniture leg. **Do not use nylon/hard plastic floor protectors or furniture feet.**

Ensure all furniture castors and chair legs are clean and free of all dirt and debris. Routinely clean chair castors and furniture legs to ensure that dirt or debris has not built up or become embedded in castors or floor protectors. Replace chair castors and floor protectors at regular intervals, especially if they become damaged or heavily soiled. Felt floor protection devices may need to be replaced 3 or more times a year to prevent accumulation. Use an effective walk-off mat or system at all outdoor entrances/exits and prevent water from accumulating. Ensure mats are manufactured with non-staining backs to prevent discoloration.

9. WARRANTY

AVA provides a 10 Year Light Commercial Warranty for 12 mil FAVE products, a 15 Year Light Commercial Warranty for 22 mil FAVE products and a Lifetime Residential Warranty for all FAVE flooring products. For additional information, see associated warranty documents.

FOR PROFESSIONAL USE ONLY. PLEASE CAREFULLY REVIEW ALL ASSOCIATED TECHNICAL DATA SHEETS, SAFETY DATA SHEETS, MAINTENANCE DOCUMENTS AND WARRANTY INFORMATION PRIOR TO INSTALLATION.